

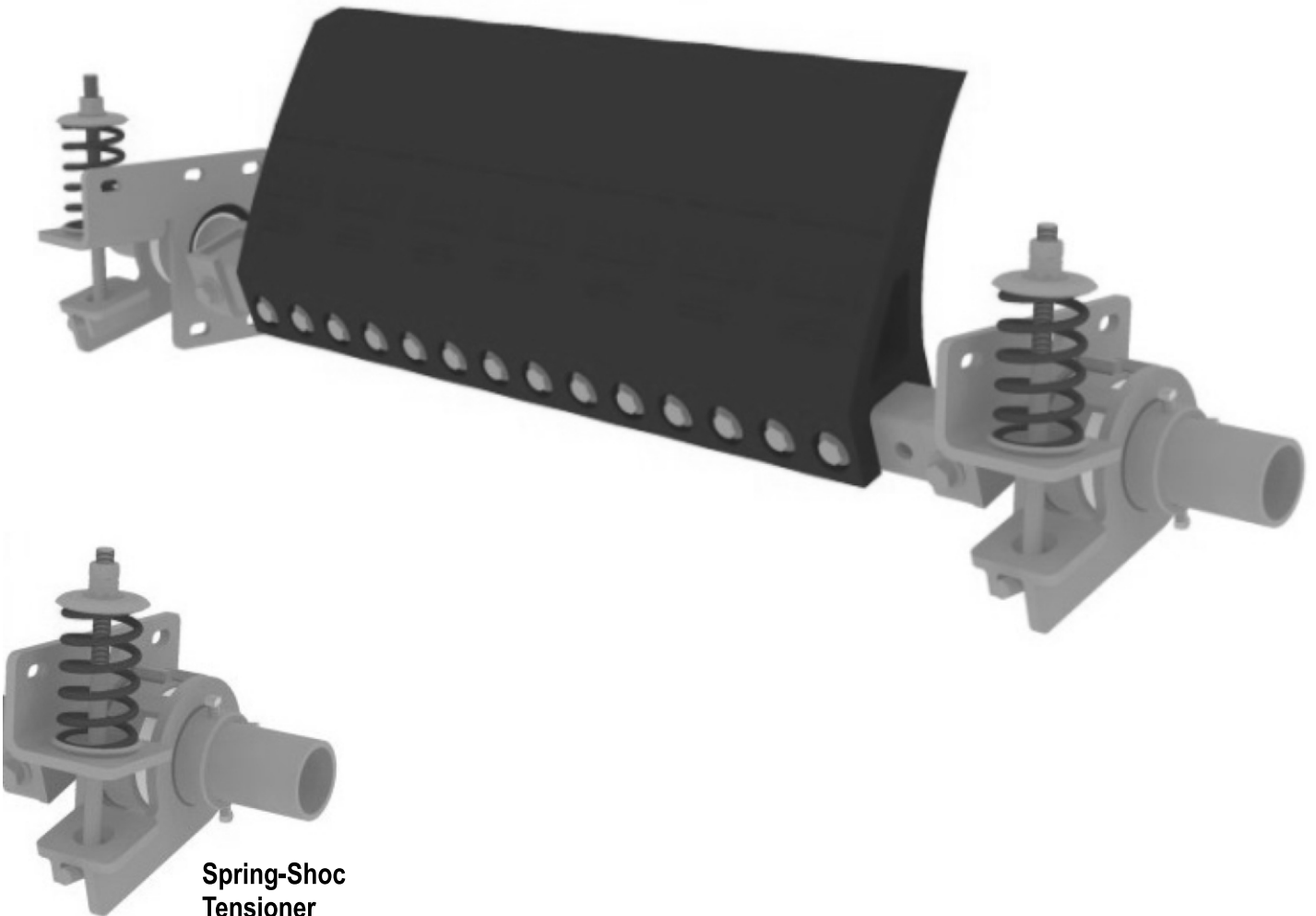

# SKALPER MDX<sup>®</sup>

WITH SPRING-SHOC TENSIONER<sup>®</sup>

## INSTALLATION, OPERATION & MAINTENANCE INSTRUCTIONS



Spring-Shoc  
Tensioner

Check us out at  
[www.asgco.com](http://www.asgco.com)

Customer Service  
**800-344-4000**



24 Hour Emergency  
Service and Parts  
610-821-0210



ASGCO Mfg., Inc.  
301 Gordon Street  
Allentown, PA 18102  
610-821-0216  
FAX 610-778-8991

## Important Safety Notice

Always observe the basic rules of safety when working with any conveyor system. To avoid injury and equipment damage, be sure that all controls to the conveyor are locked out and the power source is disconnected at all times during installation.

### Overall View

If mounting structure is not available, additional steel may have to be added. *Note: Excess mounting tube may be trimmed after installation. Also note required lubrication of components.*

### Components Diagram

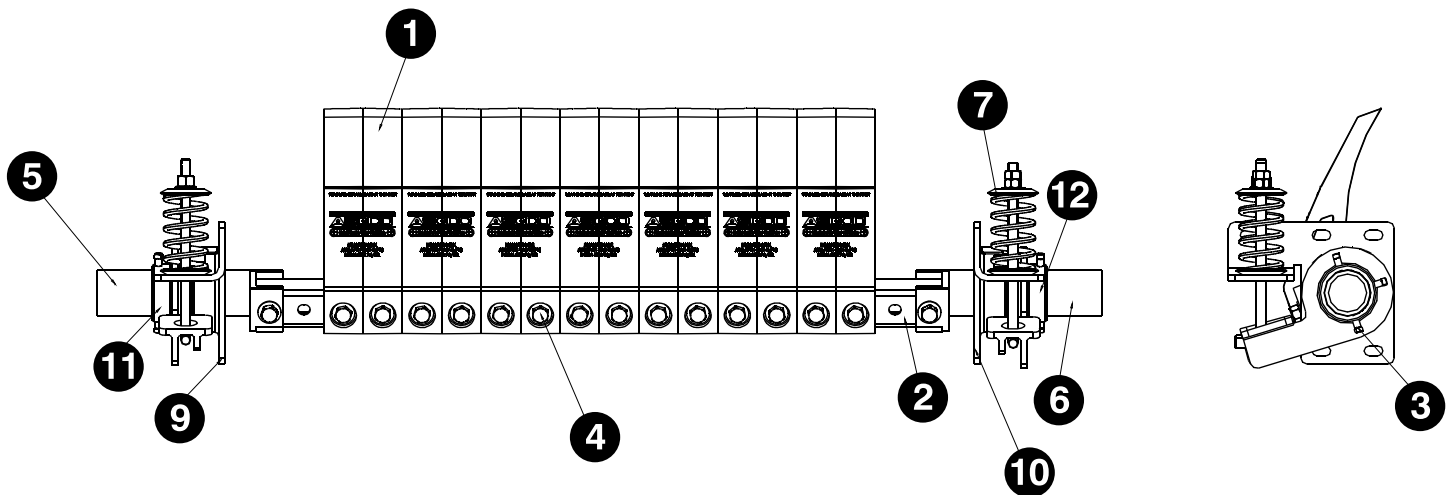

- |  |                        |
|--|------------------------|
| ① MDX Mine Duty Blade                      | ⑦ Compression Spring   |
| ② Mounting Tube                            | ⑧ Spring Shaft         |
| ③ 1/2-13 x 1 Set Screw                     | ⑨ Left Mounting Plate  |
| ④ 3/4-10 x 5-1/2 Bolt Washer<br>- Lock Nut | ⑩ Right Mounting Plate |
| ⑤ Mounting Tube Holder - Left              | ⑪ Left Torque Arm      |
| ⑥ Mounting Tube Holder - Right             | ⑫ Right Torque Arm     |

See last page for Part Number and Ordering Information

## 1. Determine the Critical “N” Dimension

The MDX Primary Cleaner is designed to be installed on pulleys as shown in Figure 1. Determining the “N” dimension, the distance from the belt surface to the mounting tube center, is critical to get maximum cleaning performance from your system. Make sure the mounting tube and tensioner system are clear of obstacles.

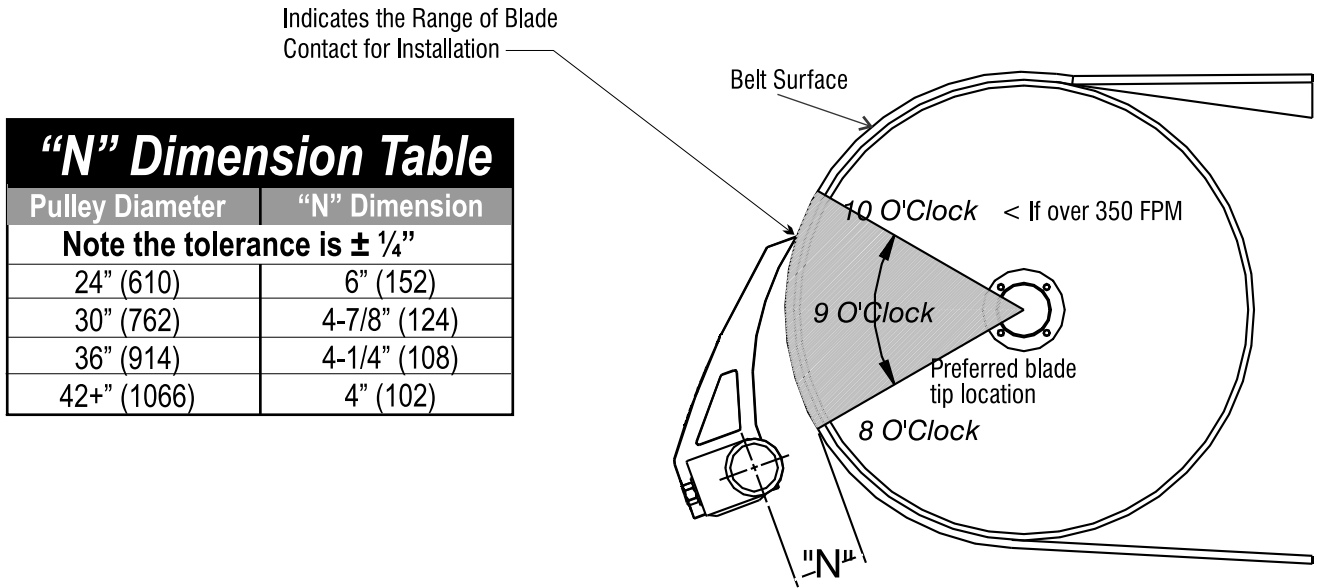

Figure 1: Typical Mounting Position

\*Note:  $\pm 1/4$ ” tolerance

## 2. Cutting the Chute Openings

Installing our MDX Primary Cleaner may require cutting access openings in your head pulley chute. Since the mounting tube can be installed last the only holes you will need on the chute sides are to allow the tube holders to penetrate inside the chute as shown in Figure 2.

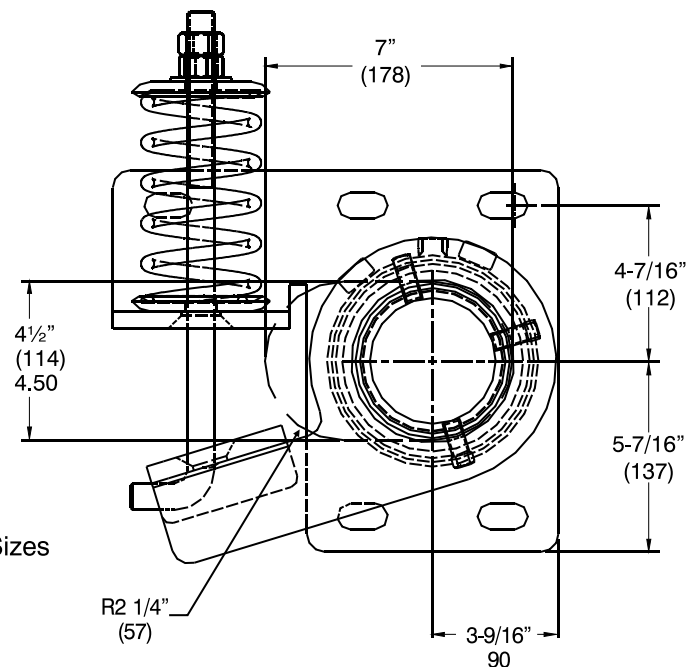

Figure 2: Slot Sizes and Location

## 4. Mounting Brackets

Determine the desired location of the mounting base. Attach the mounting base to the conveyor frame by welding or bolting.

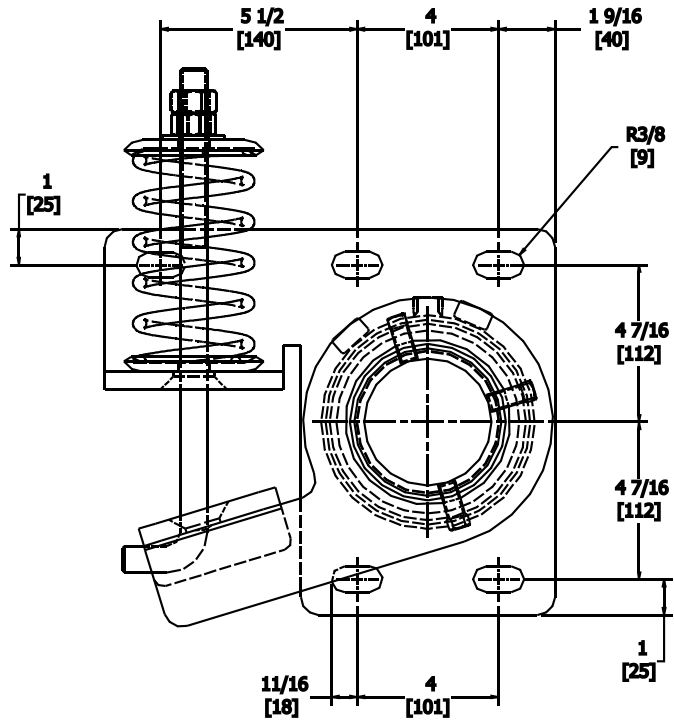

Figure 3. Mounting Hole Locations

## 5. Assembly

The Spring-Shoc Tensioner will be packaged unassembled. The package will include all of the required parts and hardware to assemble on complete Skalper MDX System. Figure 4 shows Spring-Shoc Assembly.

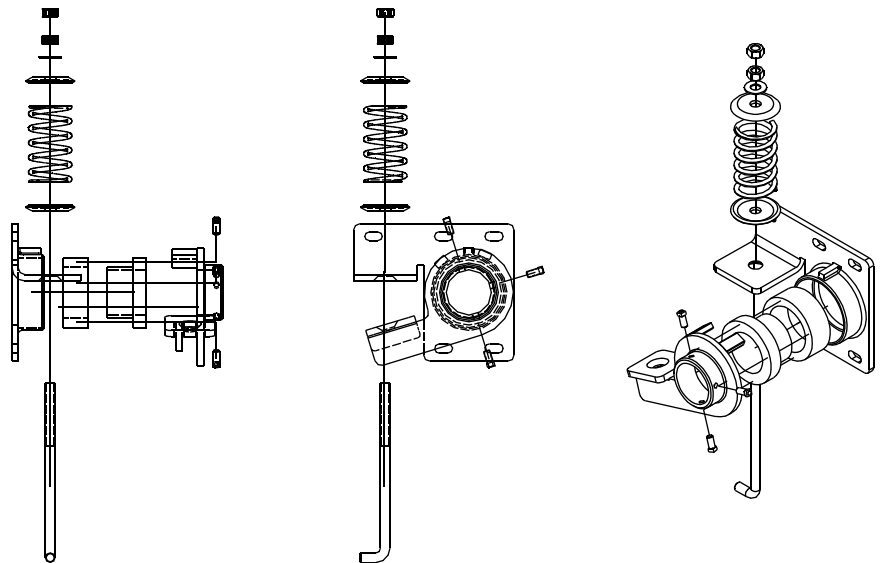

Figure 4. Spring-Shoc Tensioner Assembly

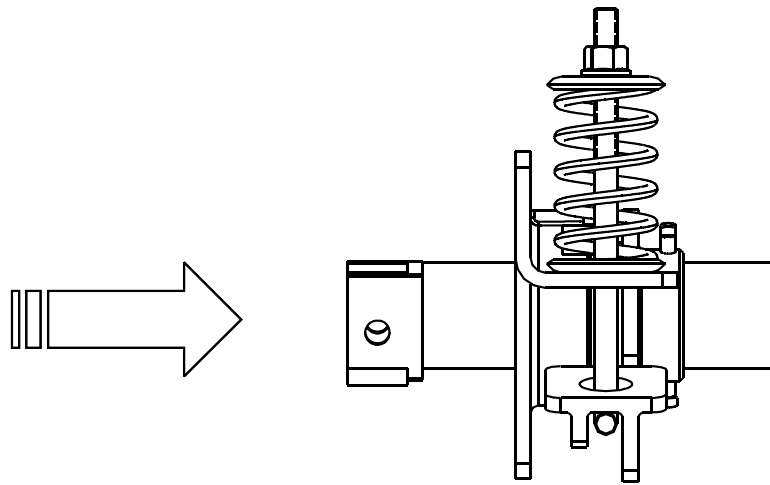

Figure 5. Insert Tube Holders into Tensioner Collars (Both Left and Right Sides)

## 5. Mounting the MDX Blades

The MDX blades can be mounted for full belt width, belt width minus 6, or belt width minus 12. To mount the blades for full belt width the blade should be mounted starting at the second hole from the end of the mounting tube. The first hole on the tube is always used for mounting the tube into the tube holder. For mounting the blades at belt width minus 6 the blades start at the third hole in from the end of the tube. To mount the blades at belt width minus 12 the blades start at the fourth hole from the end.

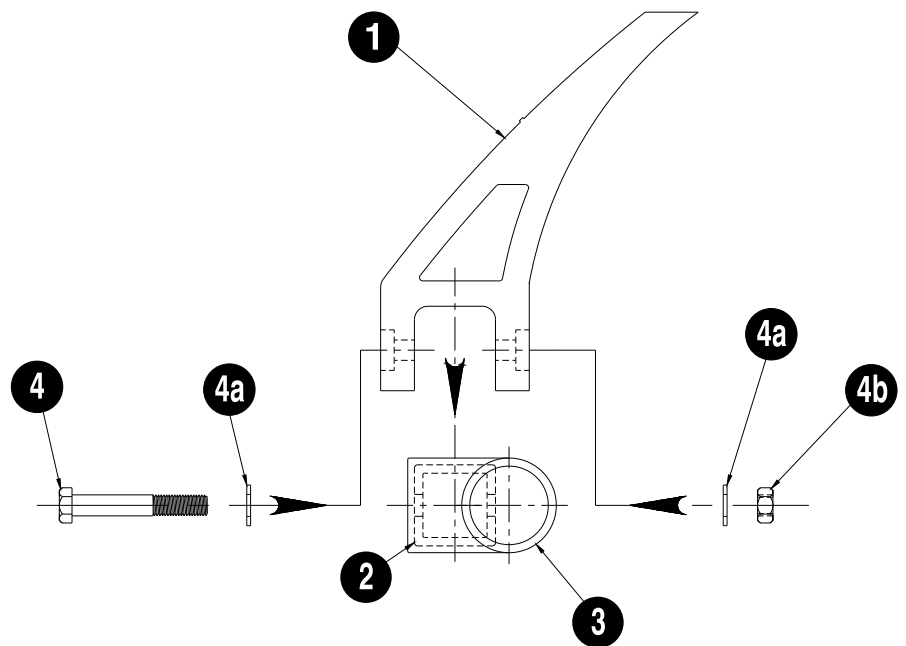
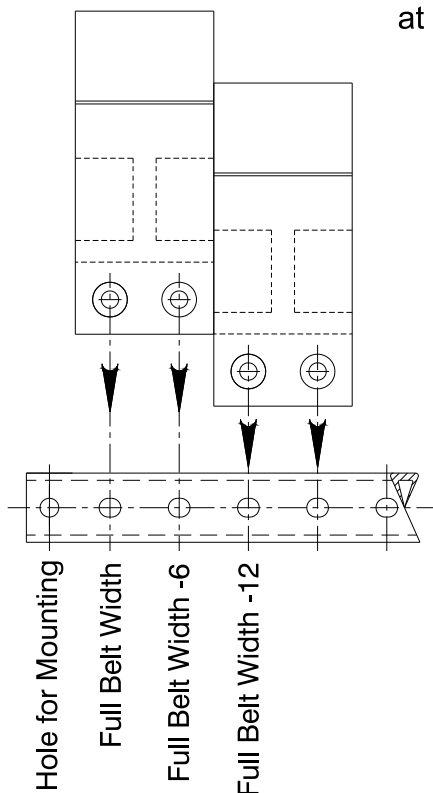

Figure 6. MDX Blade Installation

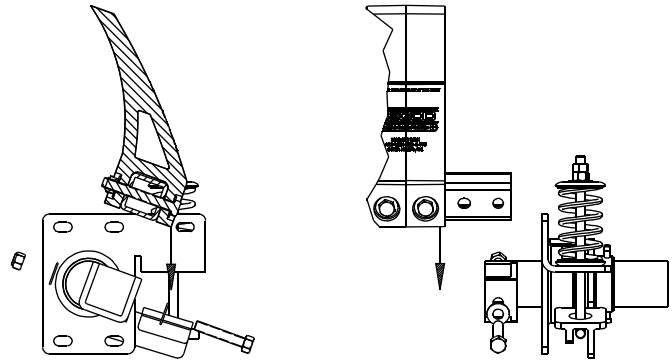

Figure 7. Mounting Tube Installation

It is recommended that the MDX Blades be installed onto the mounting tube prior to the tube being installed into the mounting tube holders. The mounting tube and blades would then have to be placed into the mounting tube holders through another access door or removable panel. Installing the Blades and Mounting Tube into the Holders is shown in Figure 7.

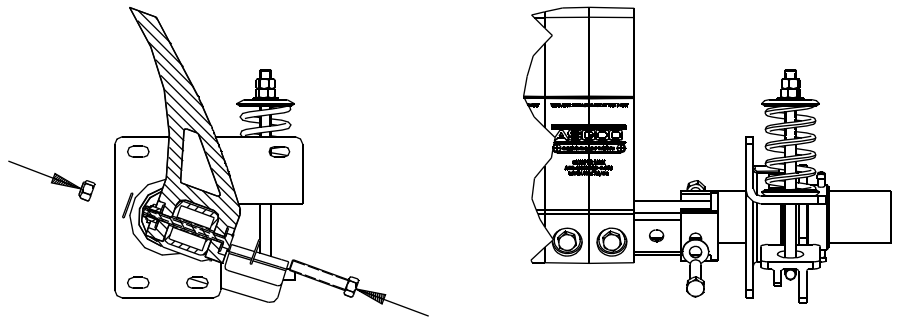

Figure 8. Bolting Mounting Tube to Tube Holders

Figure 8 shows the Tube Holders and the Blade Mounting Tube Assembly. The  $\frac{3}{4}$ -10 bolts should be torqued to 80 ft/lbs.

## 6. Setting the Tension

With assembly complete, loosely secure the compression spring in between the spring locators using the supplied 3/4-10 Nuts. Now push the MDX Skalper blades against the head pulley, now tighten the 6 set screws (3 on each torque arm collar). For a starting tension follow Table 1. Spring Shoc Tensioning Chart, The compression spring has an unloaded length of 6 inches. Compress the spring to the indicated amount tightening 3/4-10 nut and then use another nut as a jam nut.

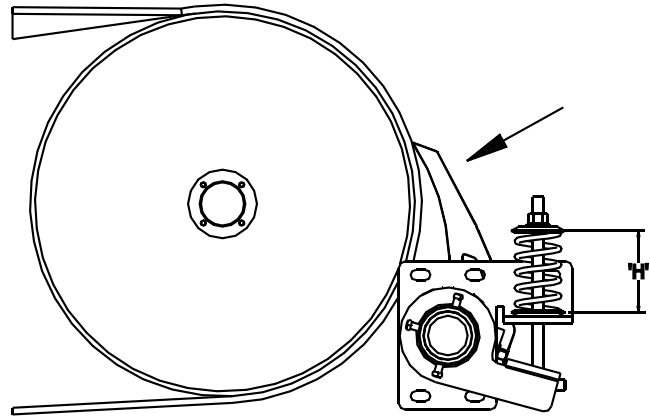

Figure 9. Spring-Shoc Tensioning

Table 1. Spring-Shoc Tensioning Chart

Belt Width (in)	Spring Height (H)	Compression of Spring
48	5 <sup>3</sup> / <sub>4</sub>	<sup>1</sup> / <sub>4</sub>
54	5 <sup>11</sup> / <sub>16</sub>	<sup>5</sup> / <sub>16</sub>
60	5 <sup>5</sup> / <sub>8</sub>	<sup>3</sup> / <sub>8</sub>
66	5 <sup>9</sup> / <sub>16</sub>	<sup>7</sup> / <sub>16</sub>
72	5 <sup>1</sup> / <sub>2</sub>	<sup>1</sup> / <sub>2</sub>
84	5 <sup>7</sup> / <sub>16</sub>	<sup>9</sup> / <sub>16</sub>
96	5 <sup>3</sup> / <sub>8</sub>	<sup>5</sup> / <sub>8</sub>

---

## OPERATION & MAINTENANCE

- 1)** Frequent inspection is the key to proper belt cleaning and easy scraper servicing. Weekly inspections are recommended, but actual service frequency may vary widely depending on various plant operating conditions.
  
  - 2)** Inspect the belt surfaces and edges for cracks, splits, tears, holes or any other worn or damaged condition occurring on the surfaces or edges of the belt itself. If necessary, make repairs to the belt. Wash the entire cleaner regularly to prevent excessive build-up. Check the tightness of all fasteners.
  
  - 3)** Inspect the cleaner for proper operation. Adjust torque as required.
  
  - 4)** Replace the MDX Skalper blade as required. Use only ASGCO Manufacturing approved replacement scraper blades.
-

## Information

1	MDX Mine Duty Blade	ASG-MDX-BLD-6-PRI	[BW] = Blade Width
2	Mounting Tube	ASG-MDX-MT-[BW]-PRI	
3	1/2-13 x 1 Set Screw	AS-SSH-1.5x1-NCG8	
4	3/4-10 x 5-1/2 Bolt	ASG-MDX-3/4X5-1/2-BOLT	
4a	3/4 Flat Washer	ASG-FW-3/4	
4b	3/4-10 Grade 5 Nut	ASG-NUT-3/4G5	
5	Mounting Tube Holder - Left	AS-MDX-MTH-PRI-L	
6	Mounting Tube Holder - Right	ASG-MDX-MTH-PRI-R	
7	Compression Spring	ASG-MDX-SS-CS	
8	Spring Shaft	ASG-MDX-SS-SS	
9	Mounting Bracket - Left	ASG-MDX-MB-SS-L	
10	Mounting Bracket - Right	ASG-MDX-MB-SS-R	
11	Left Torque Arm	ASG-MDX-SS-TA-PRI	
12	Right Torque Arm	ASG-MDX-SS-TA-PRI	
13	Shock Collar	ASG-MDX-SHOCK-COLLAR	
14	UHMW Bushing	ASG-MDX-UHMW-BUSHING-PRI	

*Call your ASGCO Distributor for any questions or replacement parts*

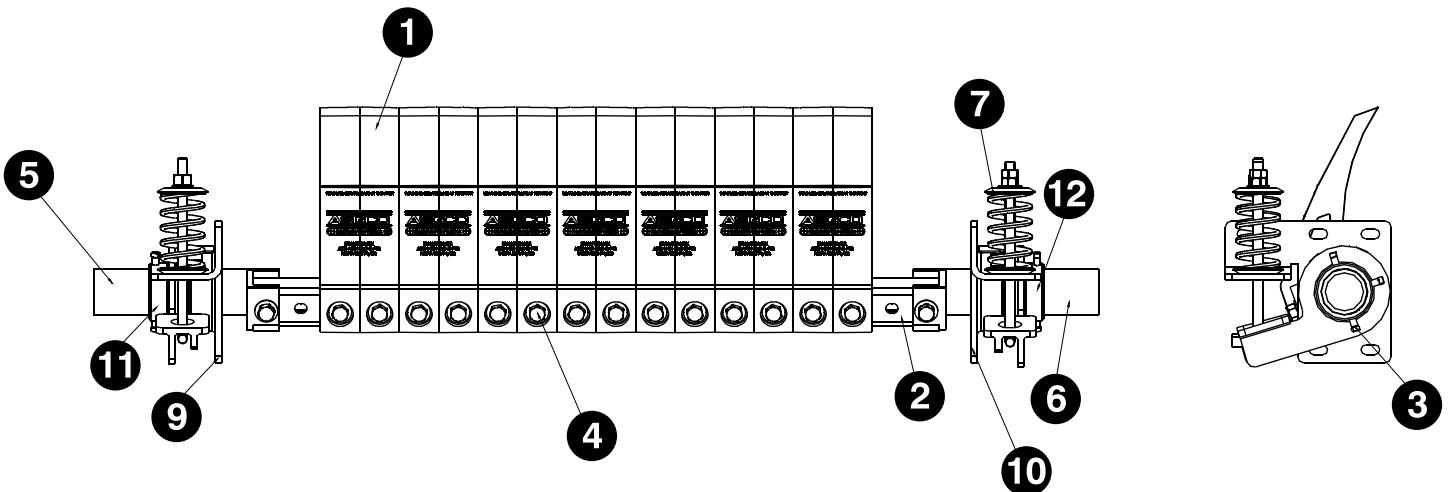

## TROUBLE SHOOTING

<b>PROBLEM</b>	<b>SOLUTION</b>
<i><b>Excess vibration of the scraper.</b></i>	<p>Make certain all bolts are tight and the pin is securely engaged on the tensioner.</p> <p>Ensure the cleaners N-dimension is proper (See Table and Figure 1).</p>
<i><b>Excess carryback.</b></i>	<p>Check for excess build-up on the scraper.</p> <p>Check for proper scraper tension. Put additional tension on cleaner.</p> <p>Check for non-uniform scraper wear.</p> <p>Check N-dimension.</p> <p>Clean the back-side of the belt cleaner.</p>
<i><b>Excessive Wear on Blade Tip</b></i>	<p>Check thickness of carry-back. If the cleaner must remove more than about 1/8" of material then additional cleaner may be needed.</p>
<i><b>Frozen Material on Scraper</b></i>	<p>Place heaters near scraper to melt frozen material. (Use caution not to burn belt or cleaner).</p>
<i><b>Blade Wearing in Center</b></i>	<p>Install a new blade that concentrates cleaning in the center of the flow of material (Belt Width -6" or Belt Width -12")</p>
<i><b>Blade Wearing More on One Side</b></i>	<p>Check N-dimension</p>